

SURFACE MOUNT LUMINAIRES EPSILON W



Approximate Dimensions:

Width: 100 mm

Length: 1235 mm

General Data:

Construction:

Body Cold Formed Sheet Metal
with high Reflectance White
Epoxy Powder Paint

Lamp Holders Positive Action Rota-lock

Ballast Available with low loss
Magnetic or high Efficiency
Electronic

IP Rating IP20

Typical

Applications:

General low cost indoor lighting Store rooms
School's
Workshops

Front View #1:

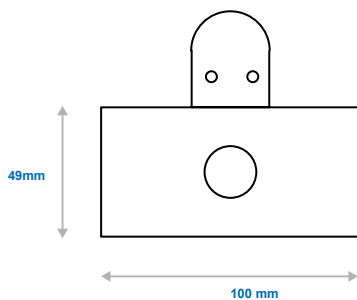

Front View #2:

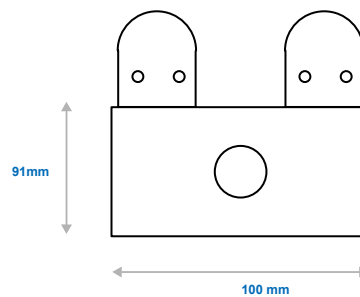

SURFACE MOUNT LUMINAIRES EPSILON W



Options:

- .../CCG (Magnetic Ballast)
- .../ECG (Electronic Ballast)
- .../ECG-EMG (Electronic Ballast with emergency back-up)

Product Information:

Product Code	LampWatt's	H (mm) Including Lamp holder	L (mm)	W (mm)	(Kg)
EP2-118	18W		625		1,7
EP2-218	2x 18W				1,8
EP2-136	36W		1235		2,8
EP2-236	2x 36W	91		100	3,3
EP2-158	58W		1535		3,5
EP2-258	2x 58W				4,7

Complete your Project:

Please select the items you require and we will be in touch

Cables and Wires:

Indoor
Outdoor
General
Other
Let an ACTOM
Specialist Contact you

Lighting:

Indoor
Outdoor
General
Other
Let an ACTOM
Specialist Contact you

Transformers (Distribution):

Indoor
Outdoor
General
Other
Let an ACTOM
Specialist Contact you

Accessories:

Indoor
Outdoor
General
Other
Let an ACTOM
Specialist Contact you

Specific Information:

Address: 4 Branch Road, Germiston 1401, P.O. Box 678, Germiston 1400

For more Information on this Product Please Send us the Following

Product Information:

Product Name:

Quantity:

Project Name:

Date the Product is required:

Your Contact Information:

Name and Surname:

Company:

Email:

Phone Number:

Province:

Thank You

For having a Look at this Product

Please send this PDF back to us with all your Information

Scan the QR Code to visit our Website:

